

Casing made of 1.25 mm Cold Rolled Steel and finished in black semi-gloss epoxy powder coat.

Umhüllung ist von 1.25 mm unvorbereitet Stahl und fertig gemacht in eine Schwarze halb-glanz Epoxy Pulver Deckanstrich.

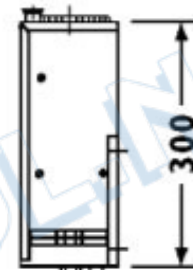
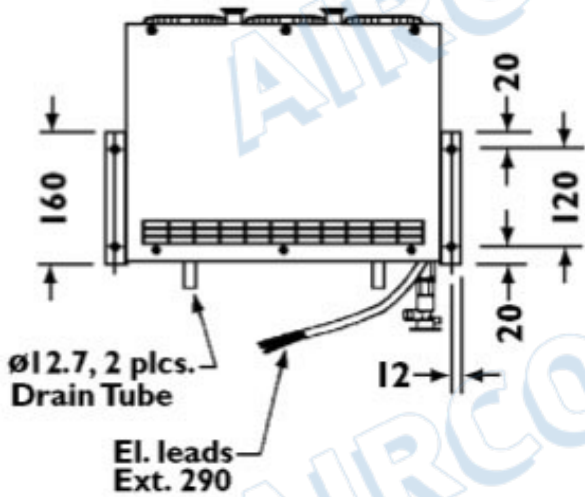

5/8"-18 Male (OR #6)  
7/8"-14 Male (OR #10)  
Refr. Hose Connection

Technical data	Technische Eigenheiten
----------------	------------------------

* Cooling capacity of matching evaporator	* Kälteleistung entspr. Verdampfer	4,60	KW
* Heating capacity	* Heizleistung		KW
* Working voltage	* Spannung	24V	Voltage
* Power consumption	* Stromverbrauch	6,5 A / 24V	
* Air flow	* Gebläseleistung	340	m3/h
* Total weight	* Gewicht	8,6	Kg

P/N: 170073

